

J-550 (031-0363)
J-551 (031-0365)

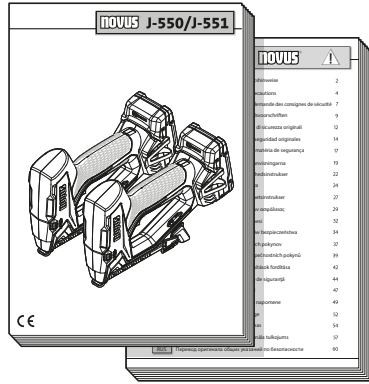

J-550 (031-0364)
J-551 (031-0366)

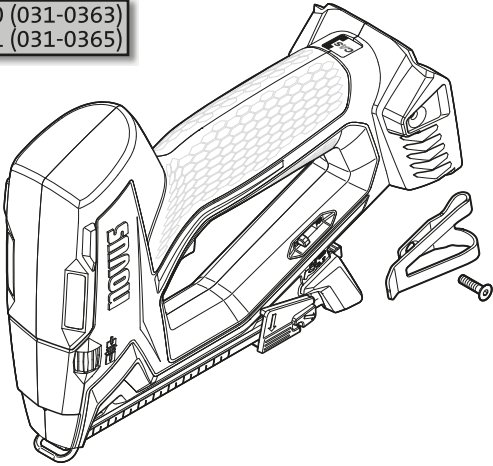
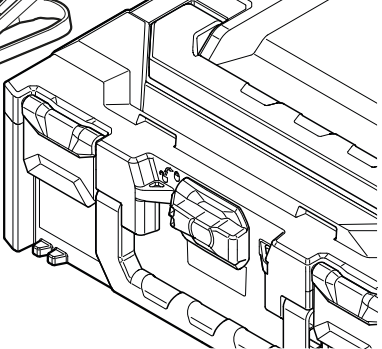
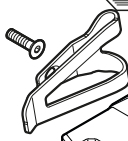
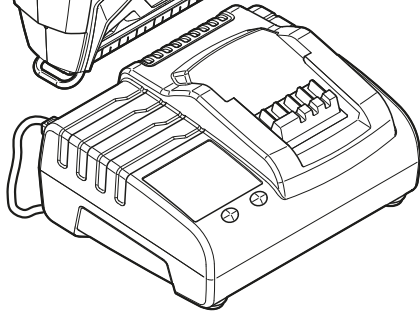
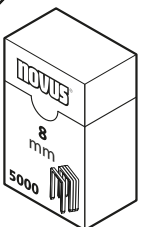
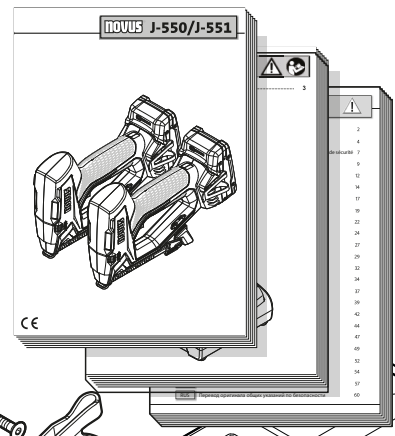
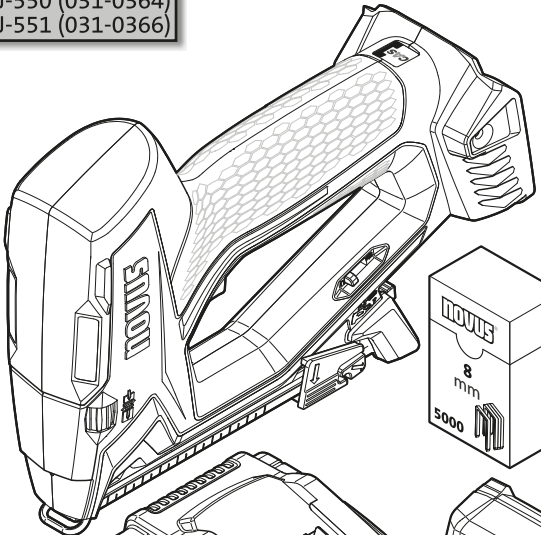

3



3.1

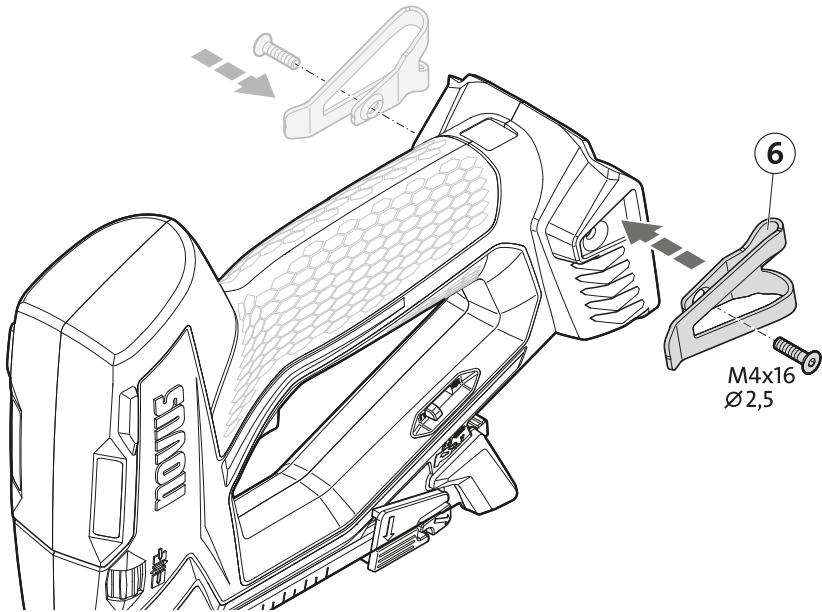

3.2

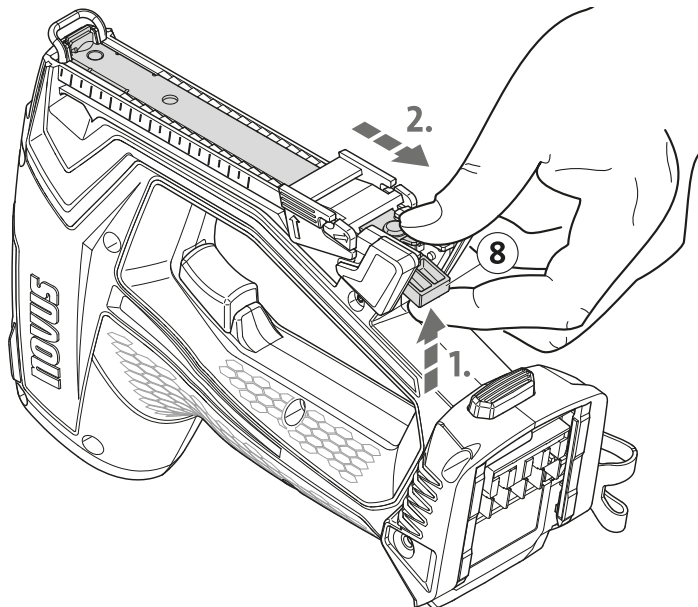
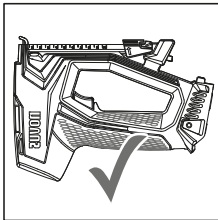
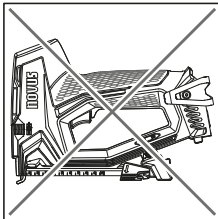

3

NOVUS® J-550 / J-551

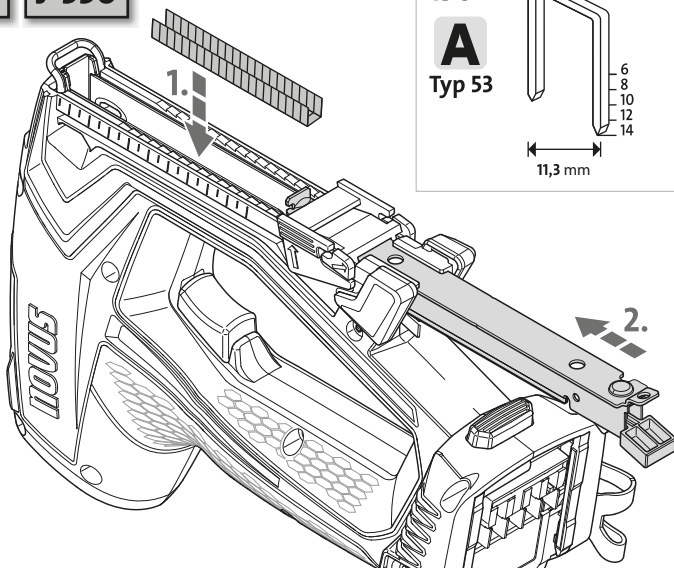
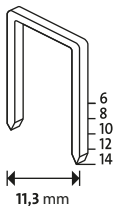
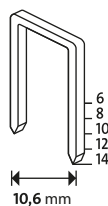
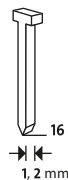
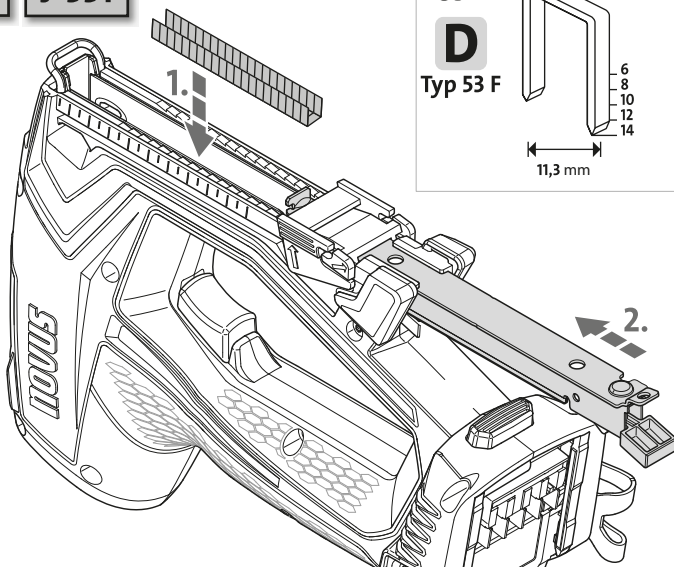
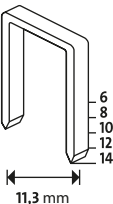
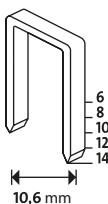
3.3 J-550

150x
A
Typ 53

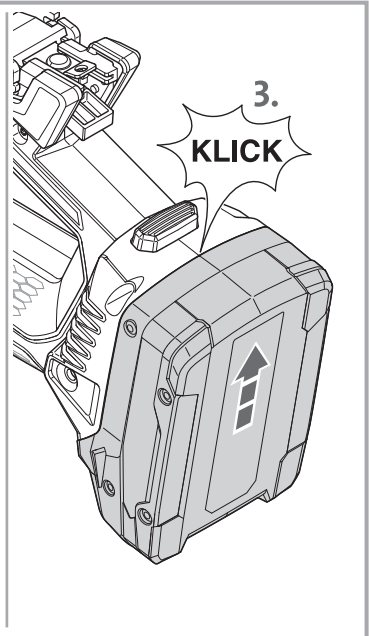
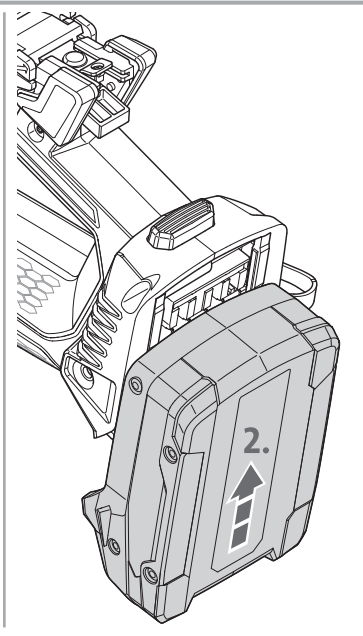
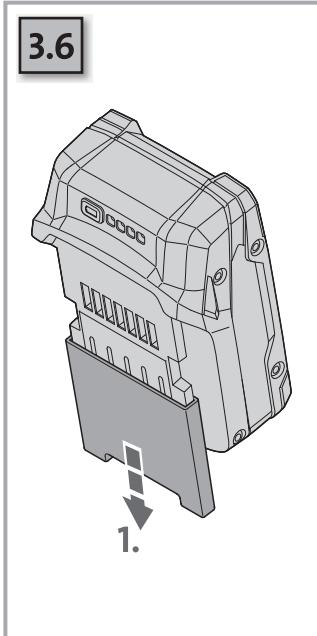
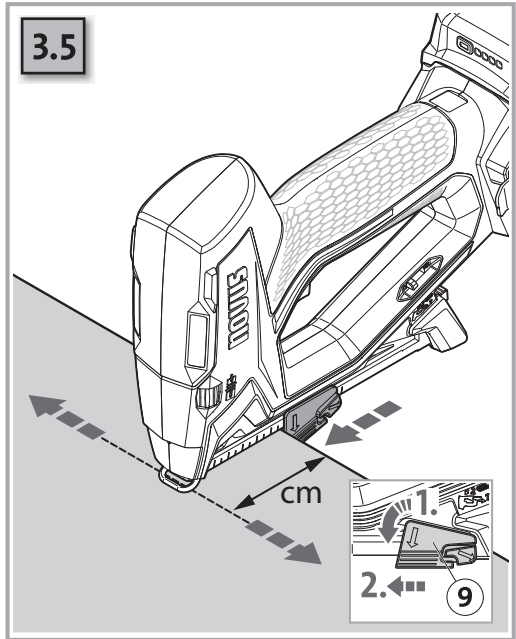
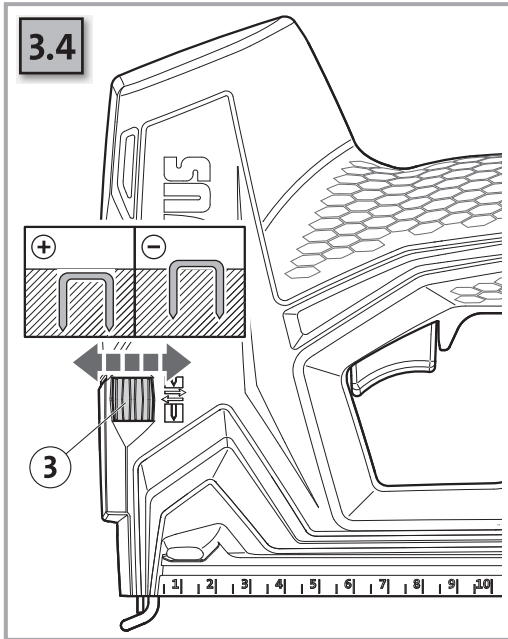
150x
H
Typ 37

85x
E
Typ J

3.3 J-551

85x
D
Typ 53 F

85x
G
Typ 11

85x
E
Typ J

3



3



NOVUS® J-550 / J-551

3.7

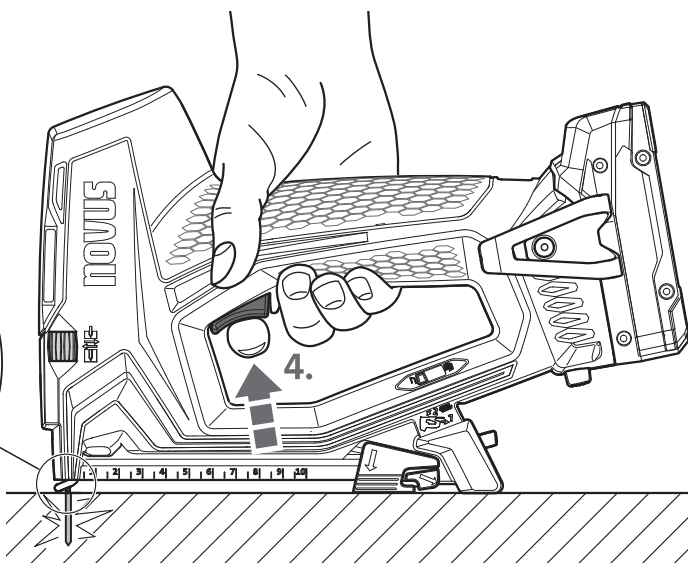
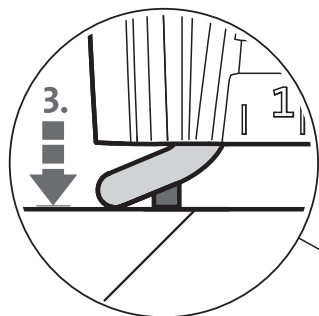
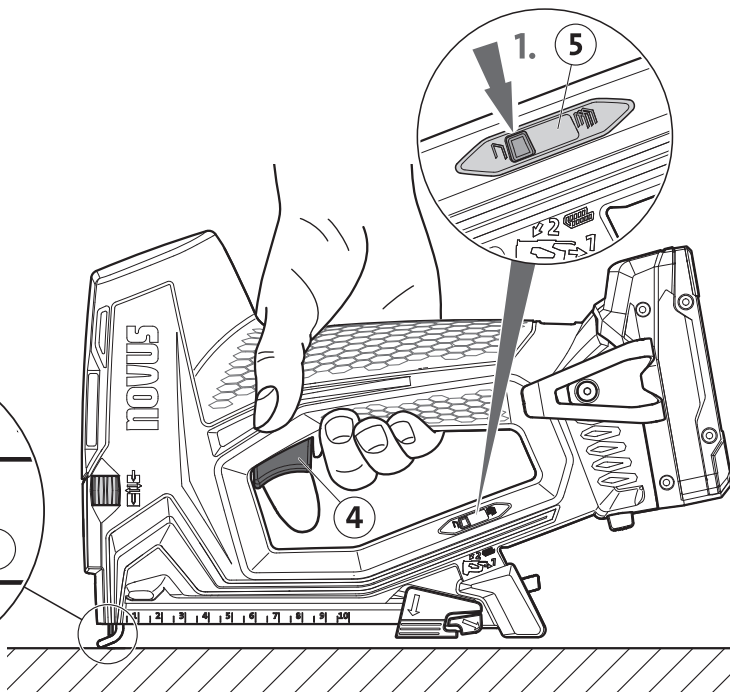
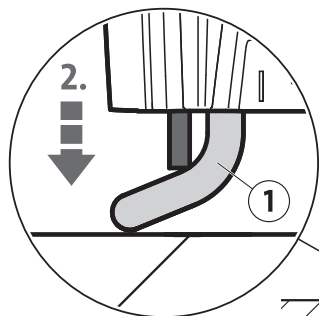
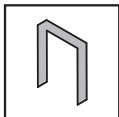

3



3.7

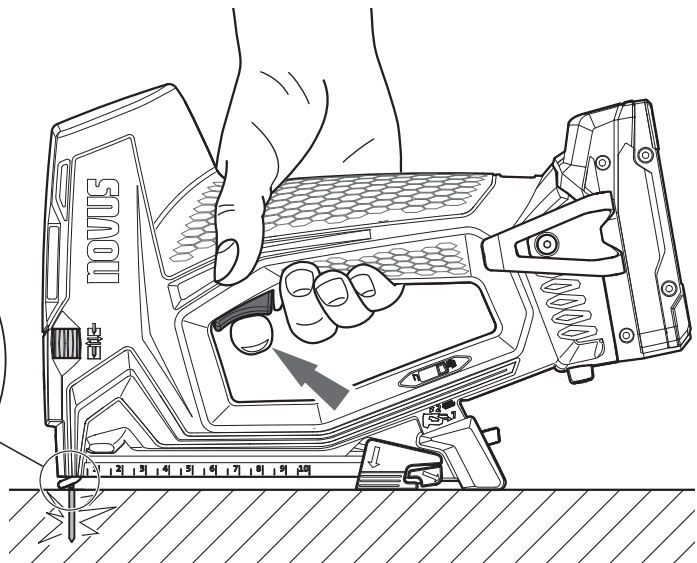
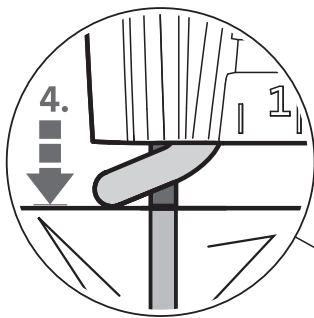
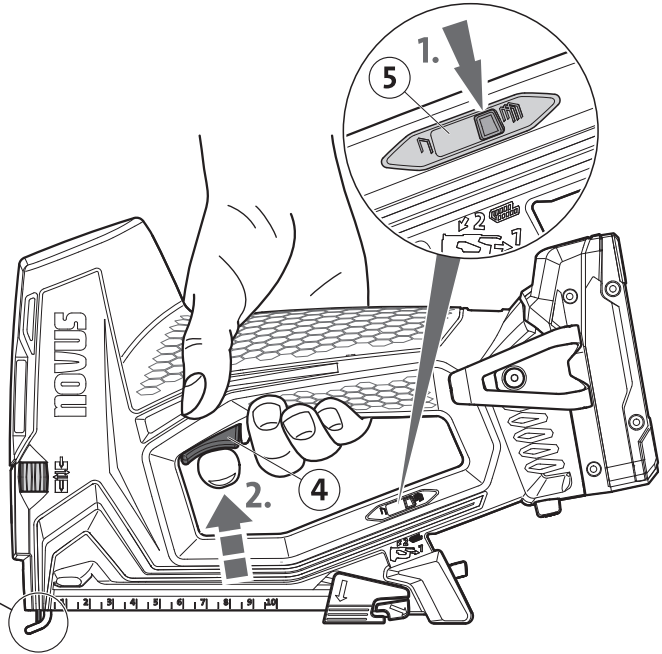
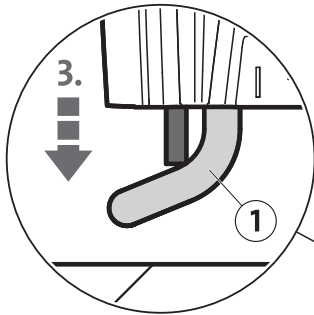

3



NOVUS® J-550 / J-551

3.8

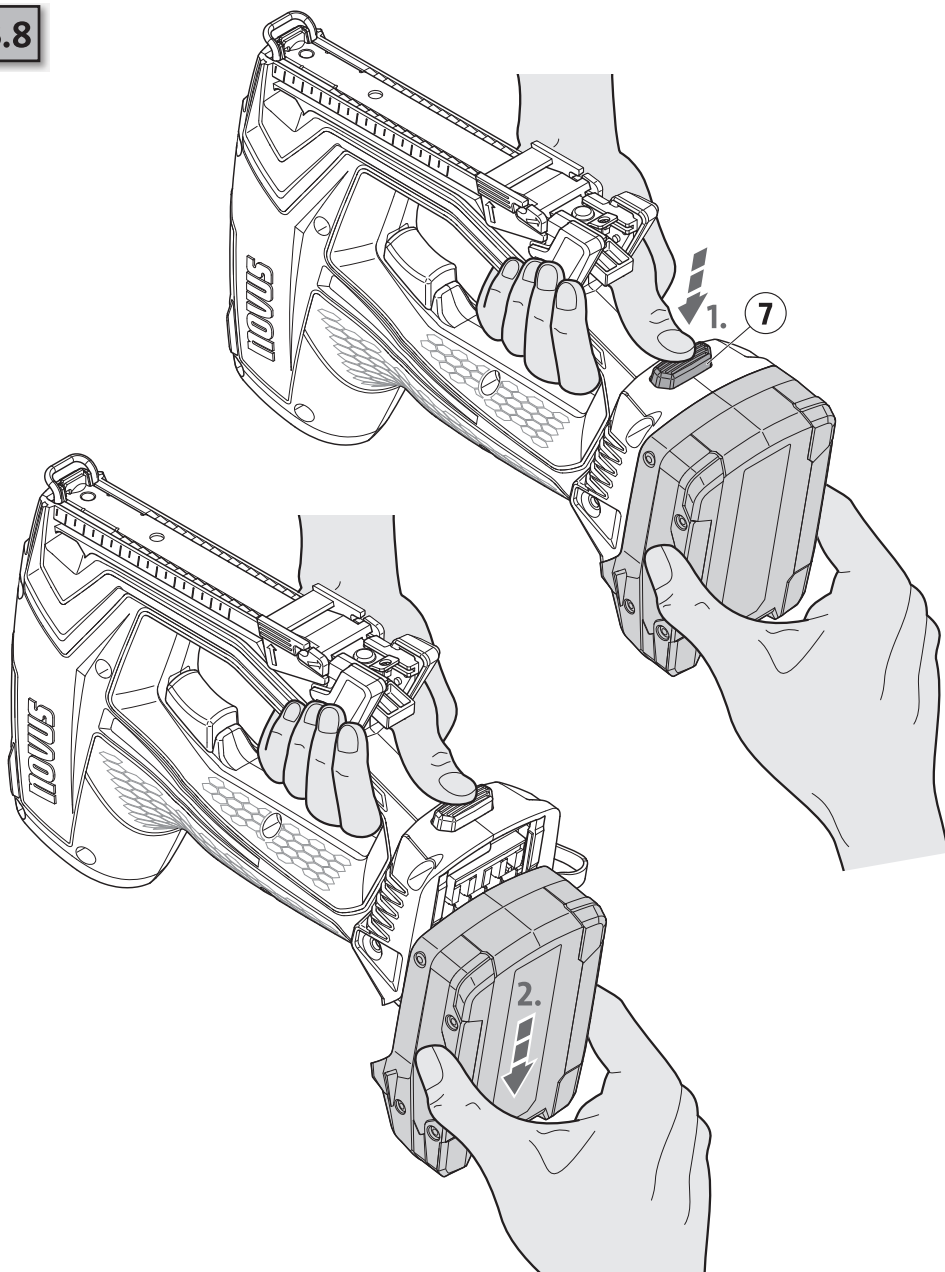

4



4.1

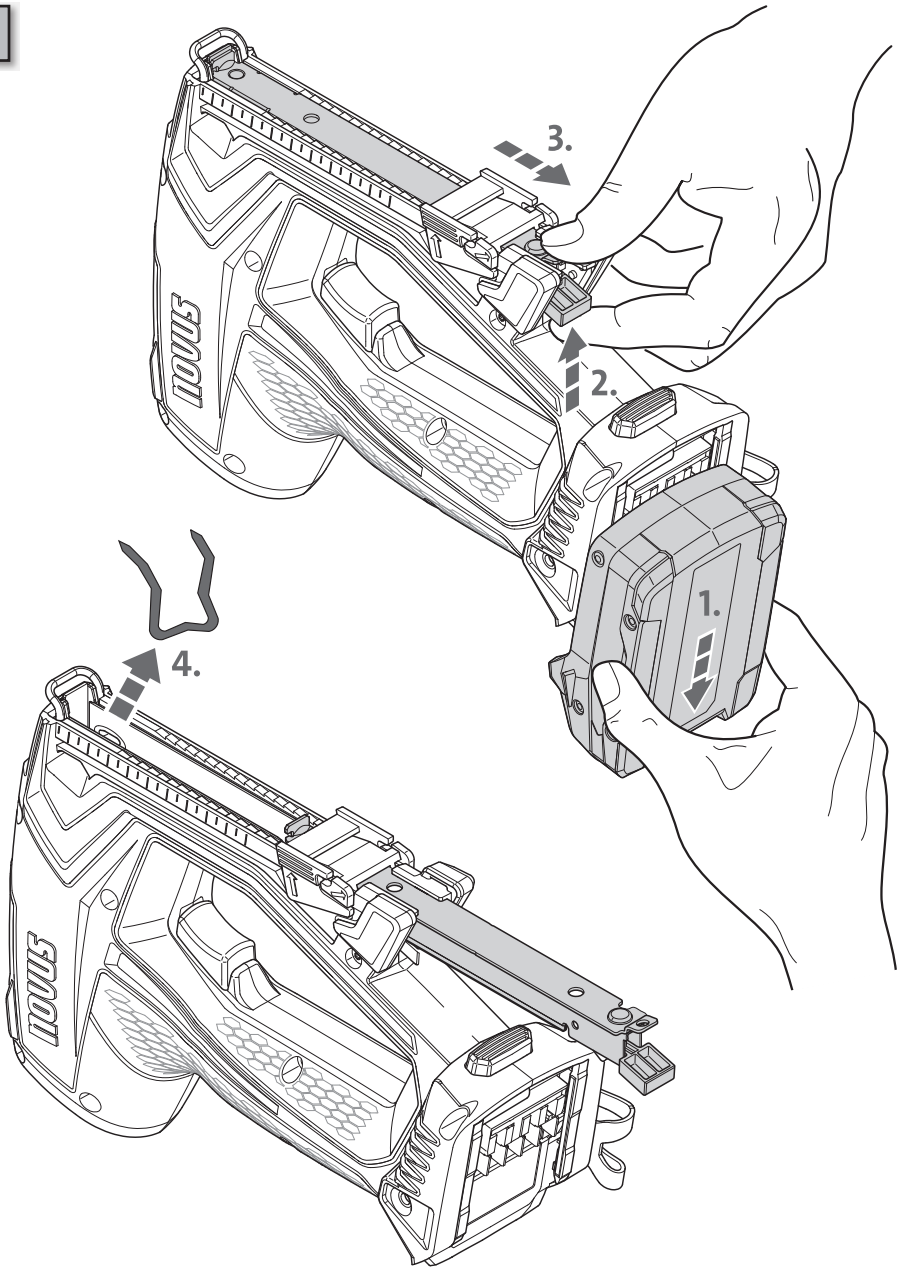

4.2

